

The VPRX Series from Valent is a high-percentage outdoor air ventilator with air-cooled packaged refrigeration and powered exhaust.

Standard construction features on the VPRX Series include:

- G90 galvanized steel formed base with 10 gage rails and 16 gage base pan
- 2" thick, polyurethane foam-injected, thermally-broken, double-wall panels with 22 gage pre-paint exterior and 22 gage G90 galvanized interior
- Hinged access doors with quarter-turn latches and identical construction to casing panels
- Direct-drive supply and exhaust plenum fan with factory provided, wired, and programmed VFD
- Fiber-reinforced, backward-inclined, non-corrosive polyamide fan wheels (supply and exhaust)
- 6-row or 4-row interlaced evaporator coil
- Indirect gas, electric, or Temperator heating (optional)
- Modulating hot-gas reheat (optional) with a minimum spacing of six inches between the evaporator and reheat coils
- Factory piped, charged, and tested air-cooled refrigeration with R-410A refrigerant (R-22 optional)
- 460/3/60, 230/3/60, or 208/3/60 power with non-fused disconnect and single-point wiring
- Factory supplied, wired, and programmed micro-processor controller
- BACnet IP, BACnet MSTP, or LonWorks communication (optional)

Specifications	VPRX 110			VPRX 210						VPRX 310			
Nominal tonnage (tons)	5	8	10	10	13	16	18	20	25	25	30	35	40
Circuits - Stages/circuit - Total stages	1-1-1	1-1-1	1-1-1	2-1-2	2-1-2	2-1-2	2-1-2	2-1-2	2-1-2	2-2-4	2-2-4	2-2-4	2-2-4
Volume <sup>1</sup> minimum (cfm)	650	1,040	1,300	1,300	1,690	2,080	2,340	2,600	3,250	3,250	3,900	4,550	5,200
Volume <sup>1</sup> maximum (cfm)	2,000	3,200	4,000	4,000	5,200	6,400	7,200	8,000	10,000	10,000	10,000	10,000	10,000
External static pressure (in.wg)	3.0	3.0	3.0	3.0	3.0	3.0	3.0	3.0	3.0	3.0	3.0	3.0	3.0
Indirect gas minimum (mbh)	100	100	100	200	200	200	200	200	200	400	400	400	400
Indirect gas maximum (mbh)	150	200	200	350	400	400	400	400	400	700	800	800	800
Electric heat <sup>2</sup> minimum (kW)	10	10	10	15	15	15	15	15	15	20	20	20	20
Electric heat <sup>2</sup> maximum (kW)	80	80	80	80	100	100	150	150	150	150	150	150	150
Temperator electric heat <sup>3</sup> (kW)	6	9	12	12	15	18	21	25	28	28	34	44	55

<sup>1</sup> Volumes shown are based on fan performance and not cooling capacity. When designing for 100% outdoor air applications, size unit for approximately 150 cfm/ton.

<sup>2</sup> Temperator electric heat is to be added to the basic capacities of the indirect gas furnace. For more information, please see Valent's Temperator Marketing Bulletin.

<sup>3</sup> Electric heat capacities shown at 460V. Capacities may be less for 230V, 240V, and 208V.

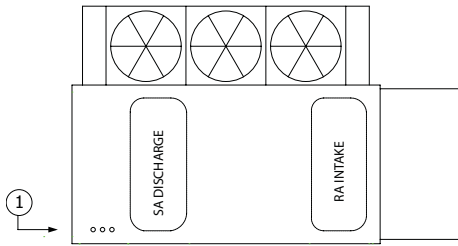

**Notes:**

- 1. Through-base electrical connections
- 2. Supply fan access door
- 3. Evaporator coil access door
- 4. Supply air filter access door
- 5. Outdoor air intake hood with birdscreen
- 6. Lifting lug (typ. of 4)
- 7. Powered exhaust module
- 8. Compressor section access door
- 9. Electrical panel access door

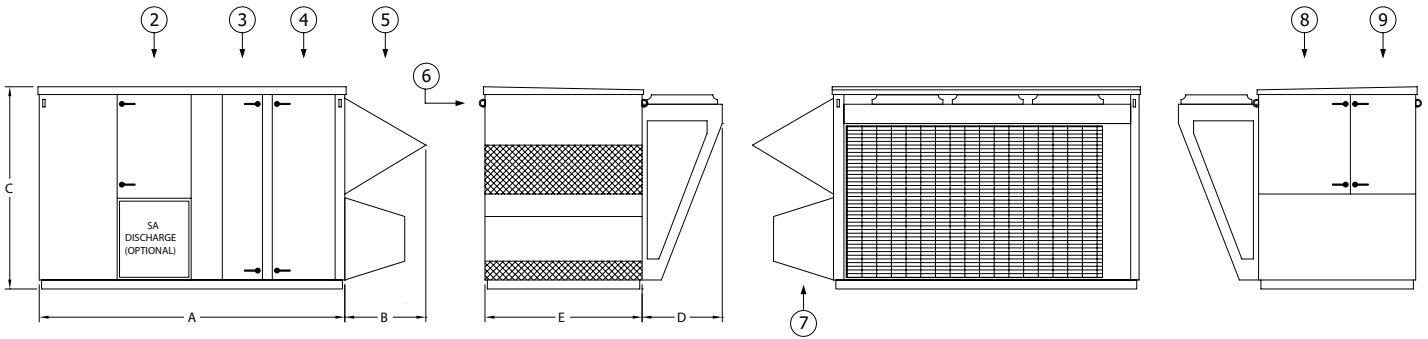

	VPRX 110			VPRX 210						VPRX 310			
Nominal tonnage (tons)	5	8	10	10	13	16	18	20	25	25	30	35	40
Nominal weight (lbs)	2,000	2,100	2,200	2,600	2,800	3,000	3,200	3,400	3,600	4,300	4,500	4,700	4,900
A (in)	158			168						178			
B (in)	22			24						34			
C (in)	57			64						84			
D (in)	32			32						34			
E (in)	48			61						67			